

AMZ/G Solar

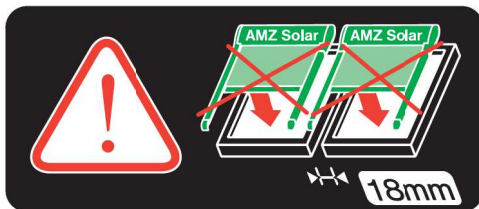

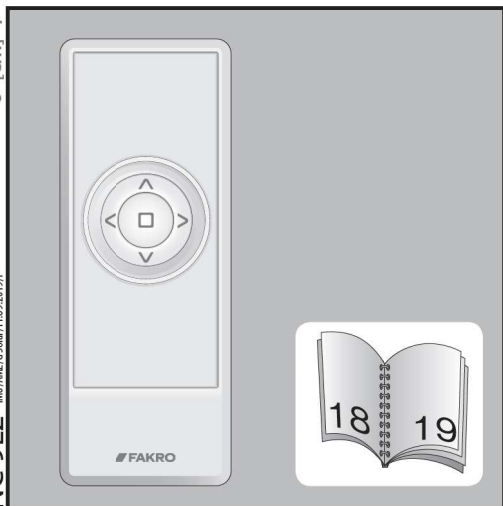
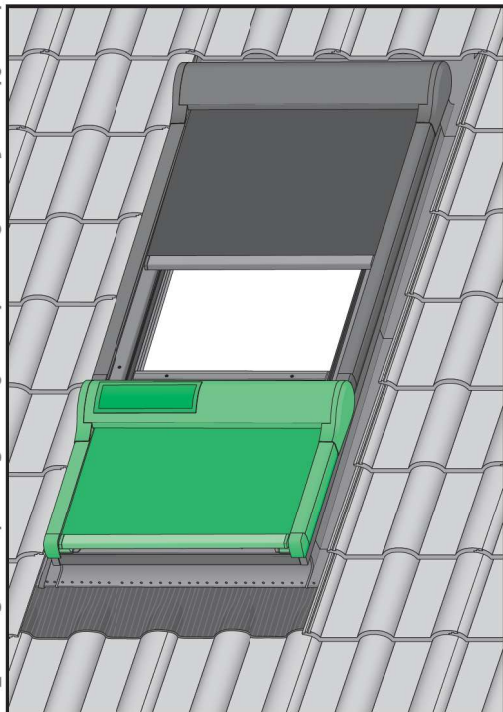
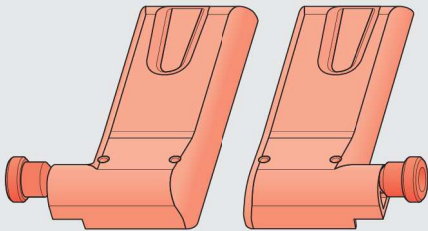
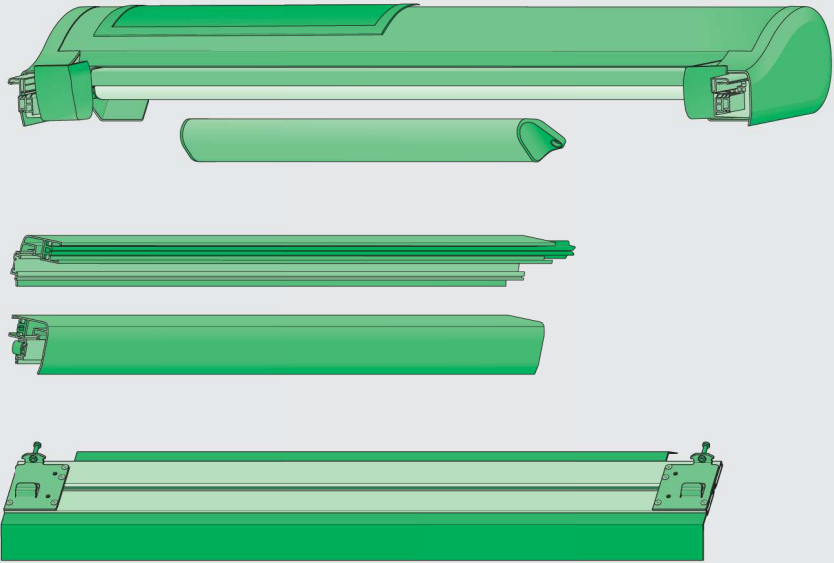

JJ 253

JJ 254

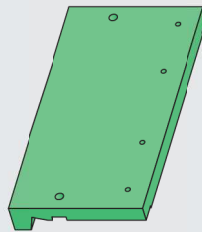

x1



x4

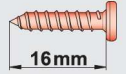

x2

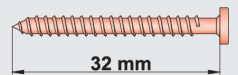

x4

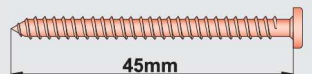

x6



Ø 2,5mm

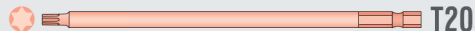

T20

1a

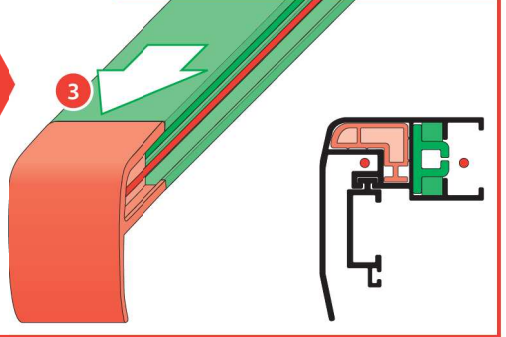
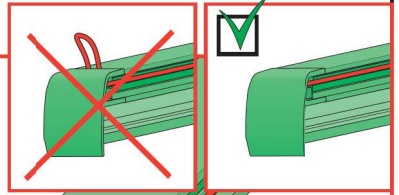
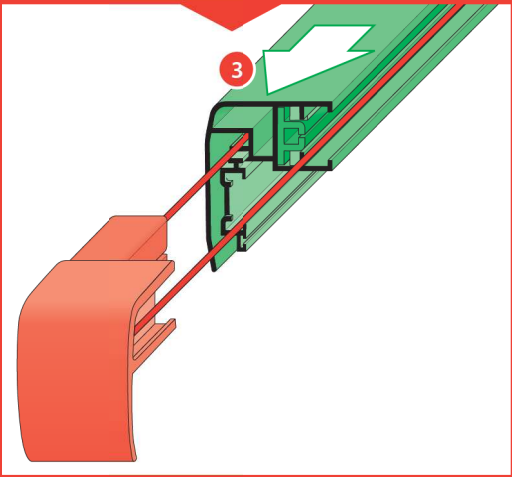
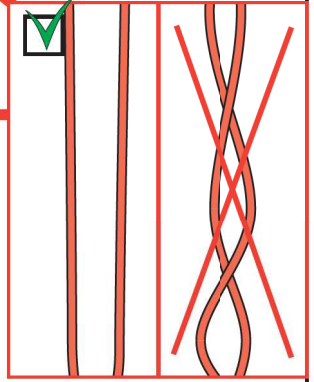
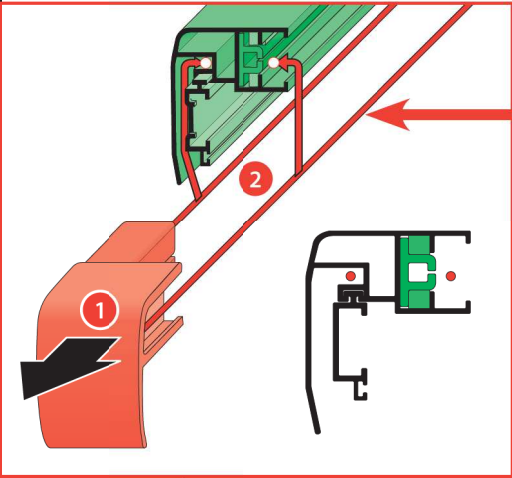
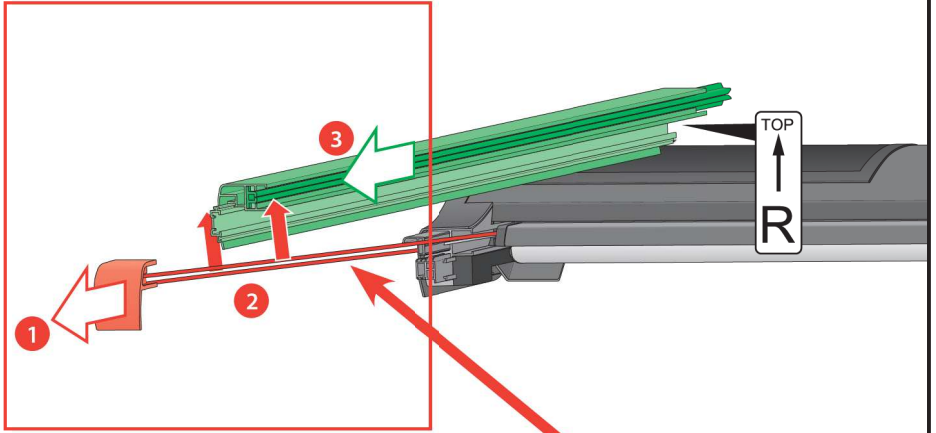

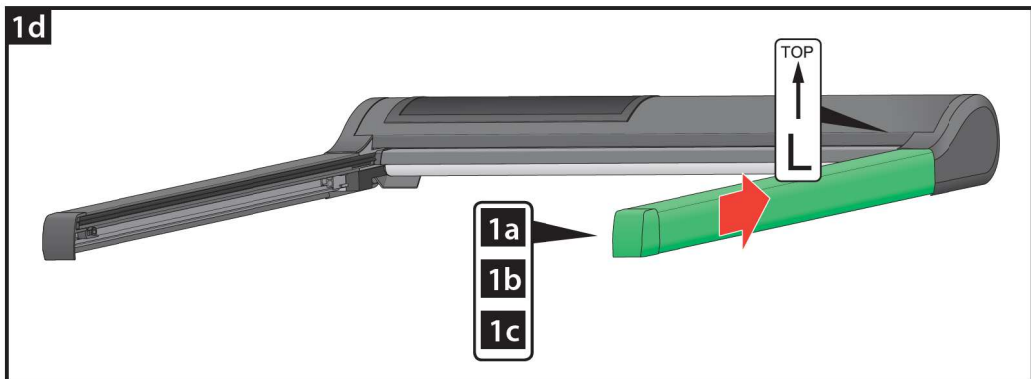
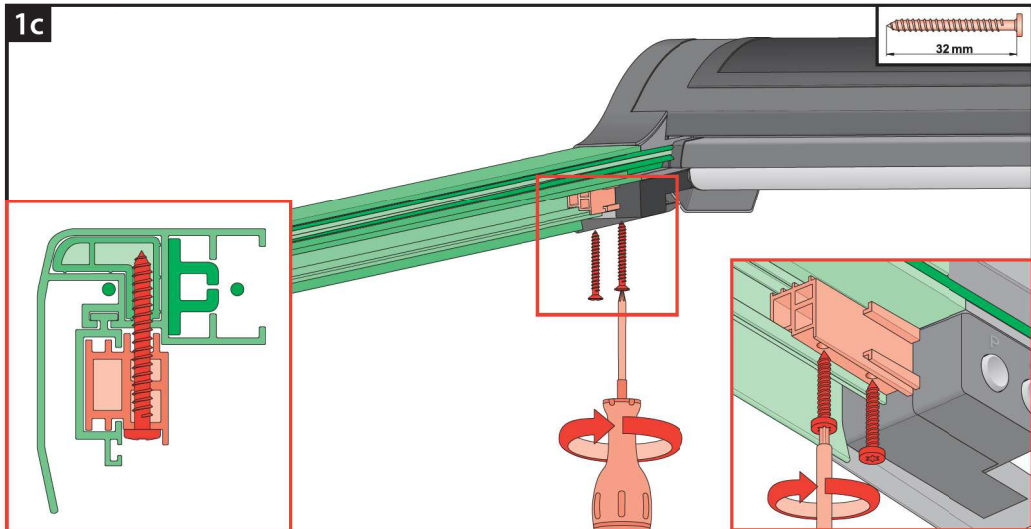
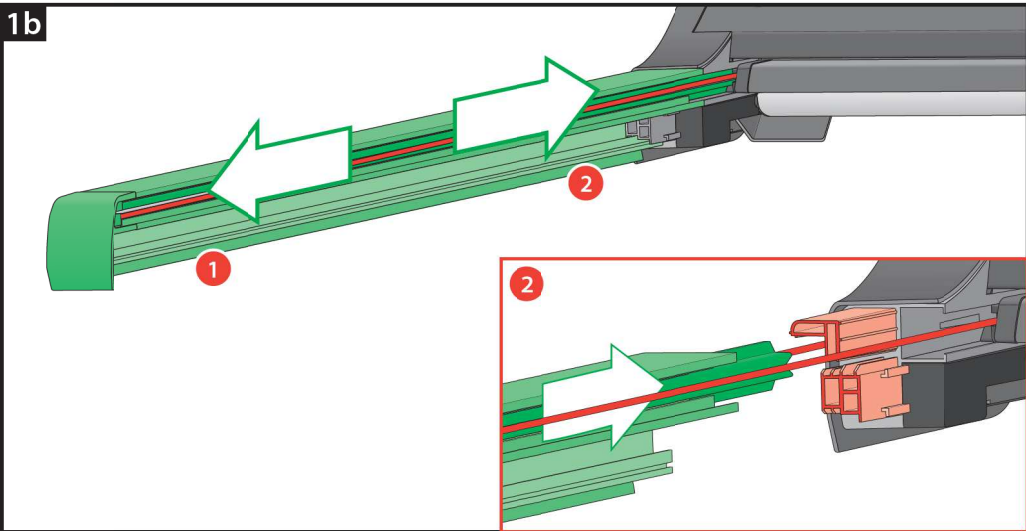

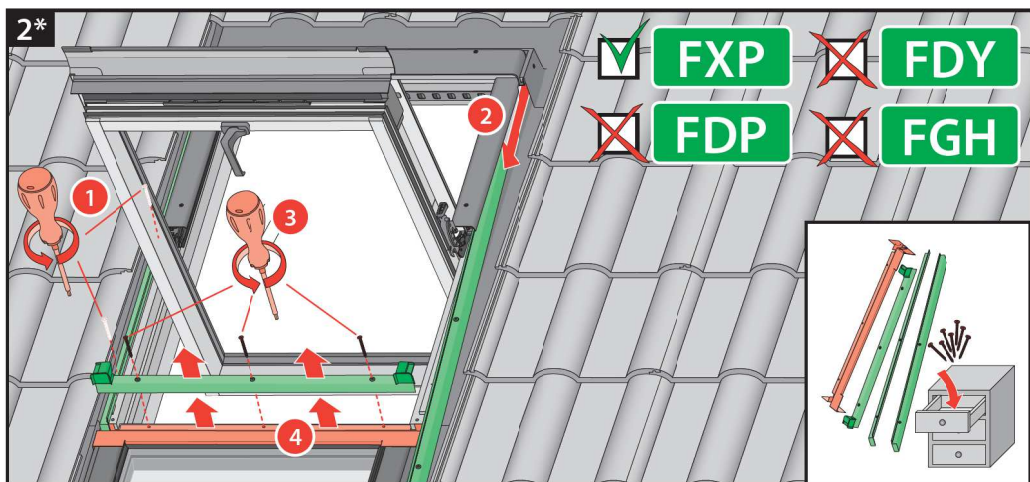
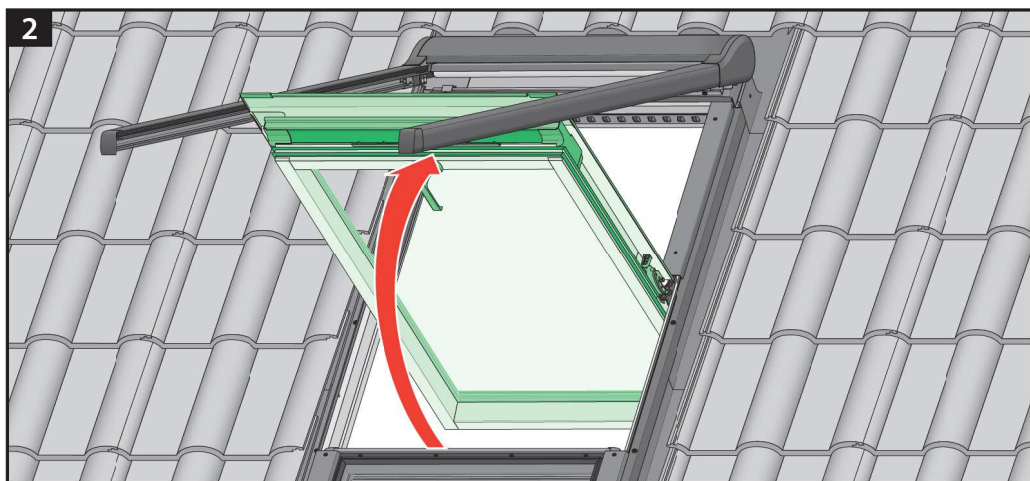
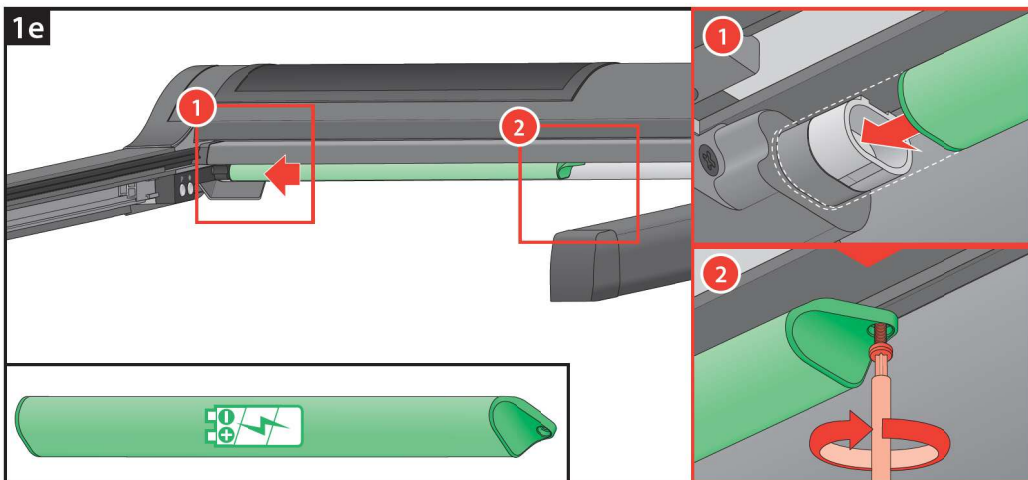

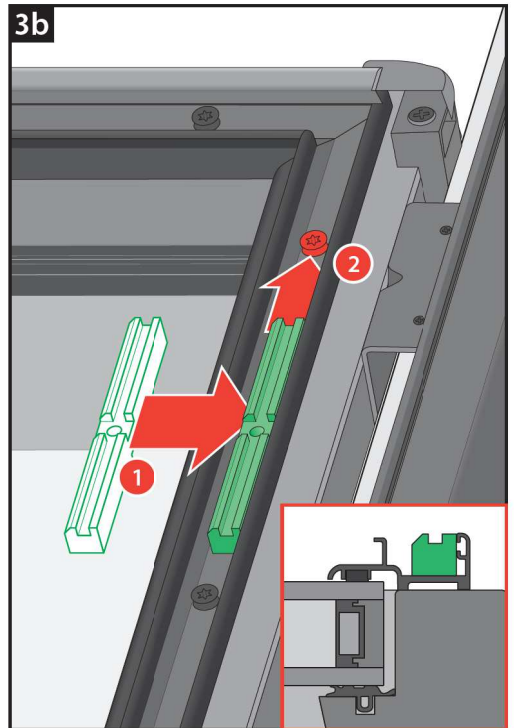
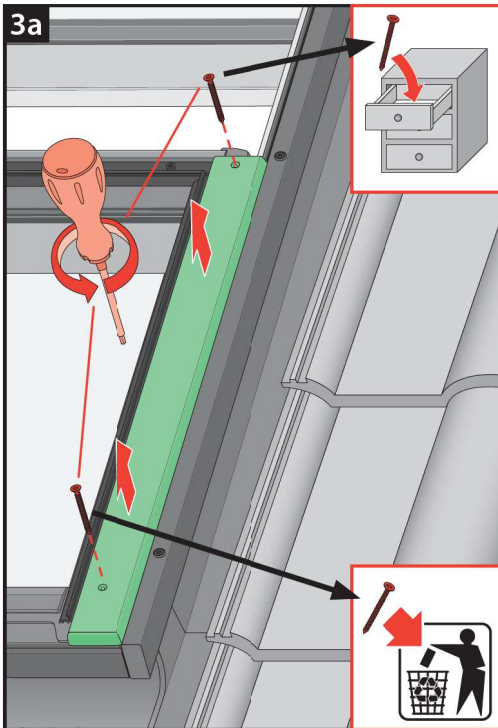
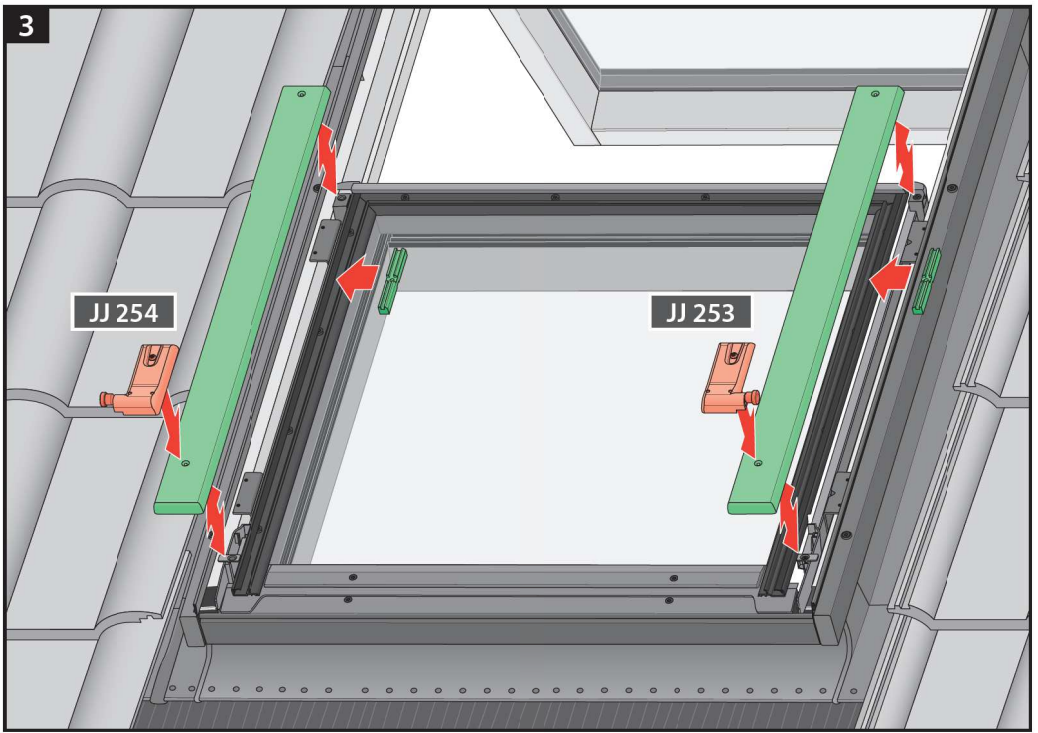

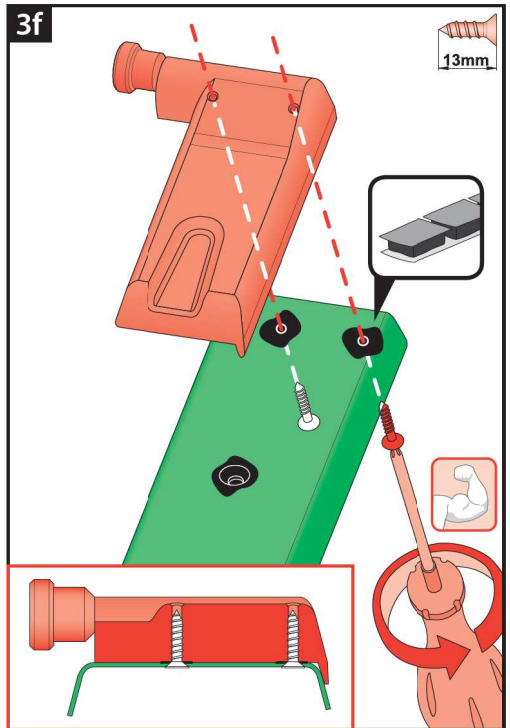
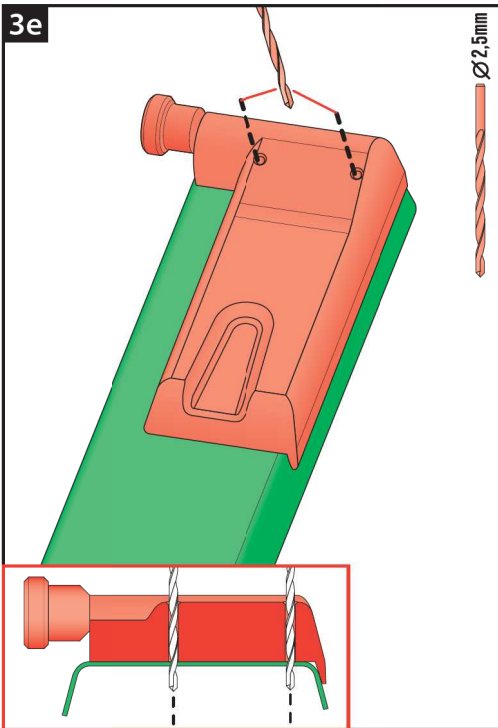
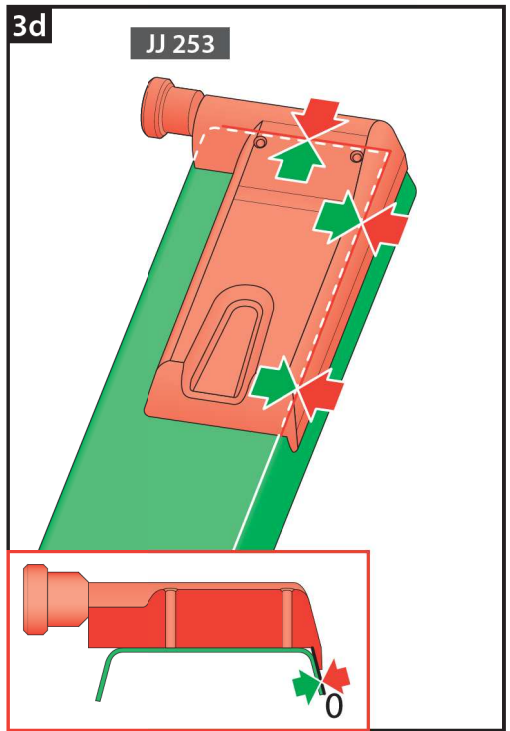
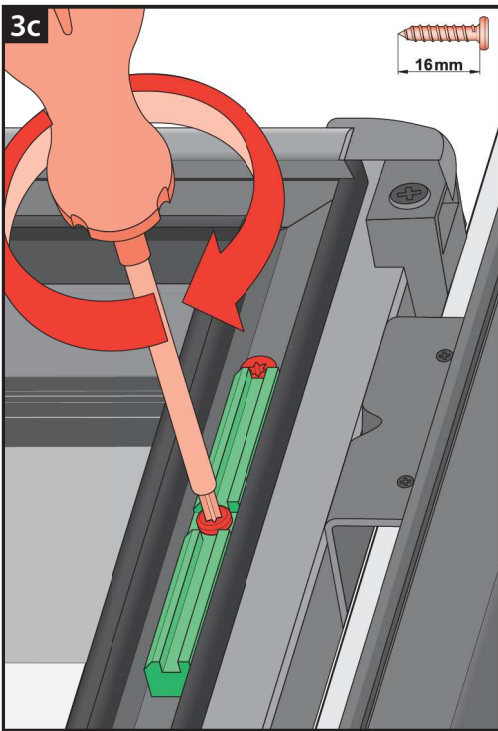

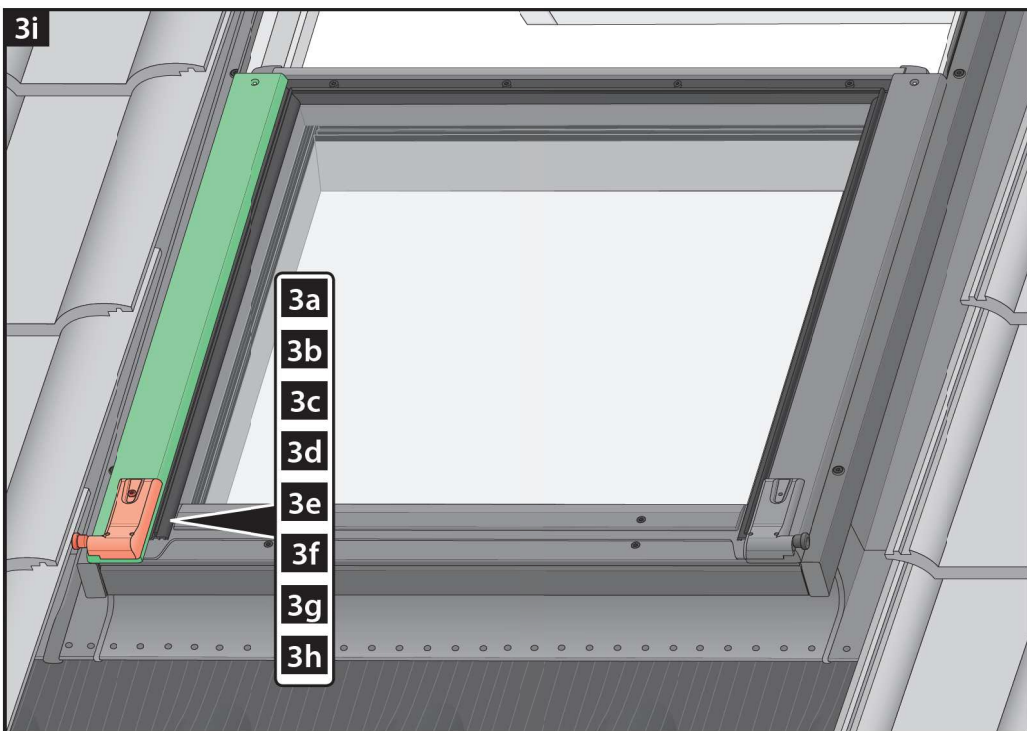
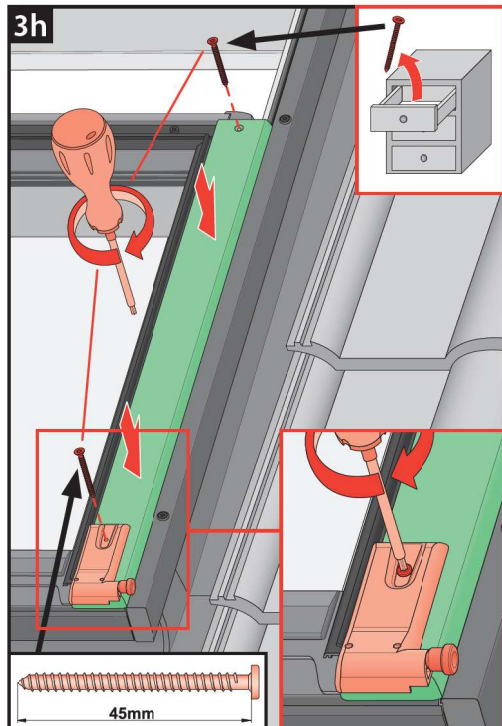
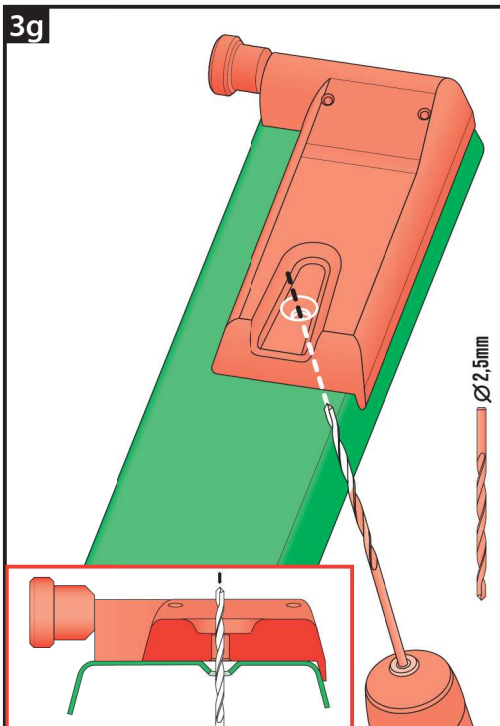

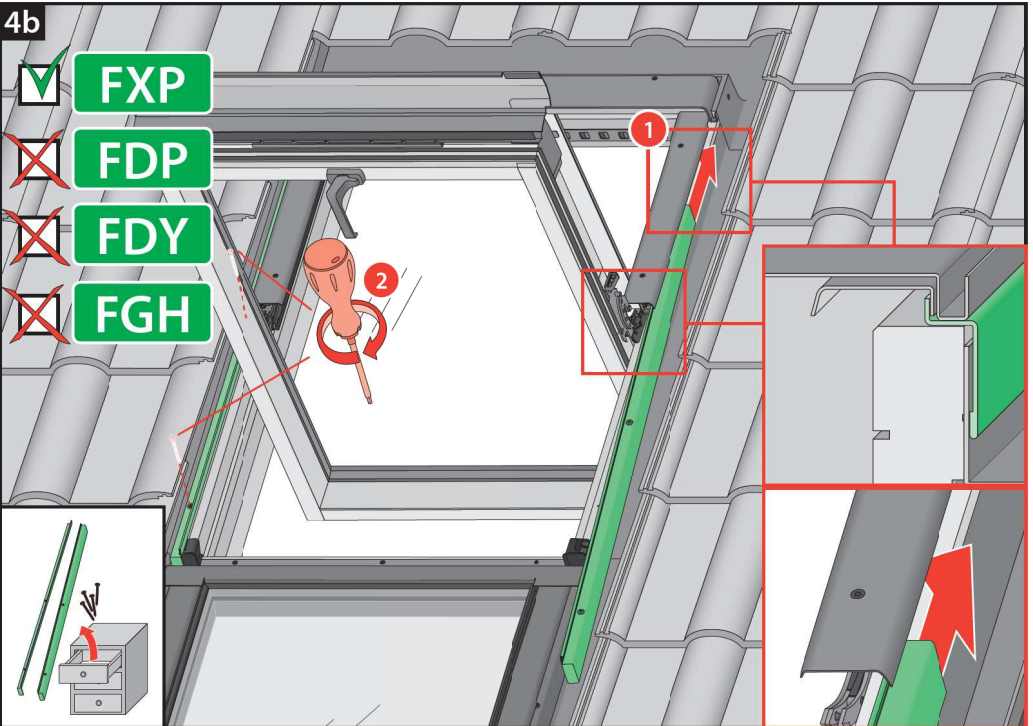
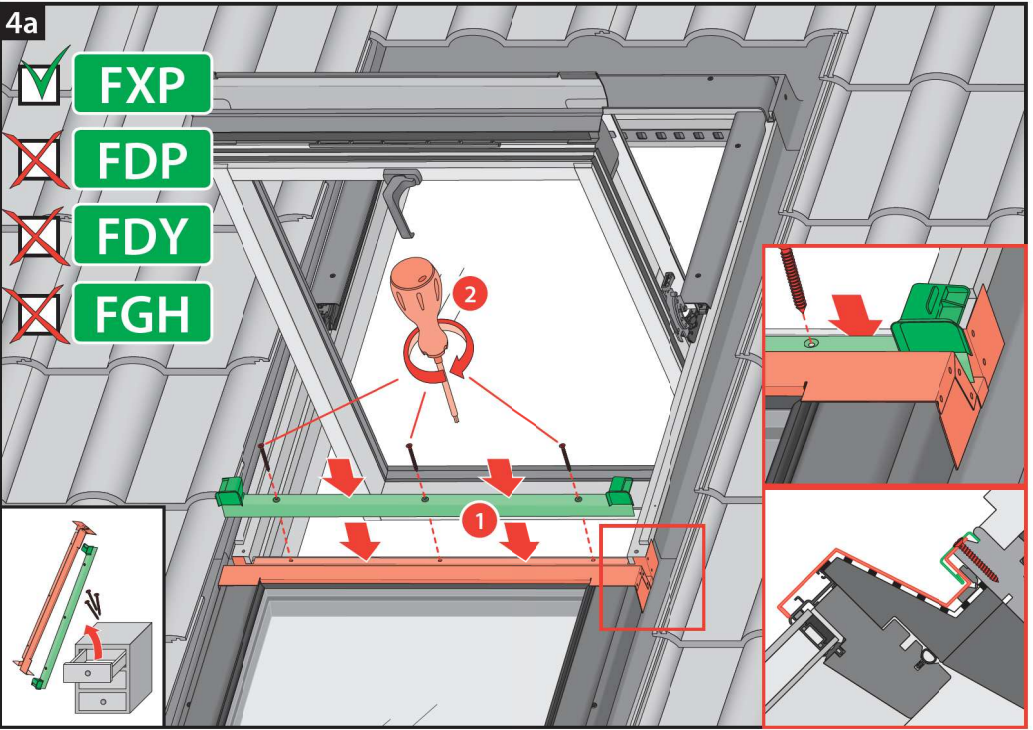

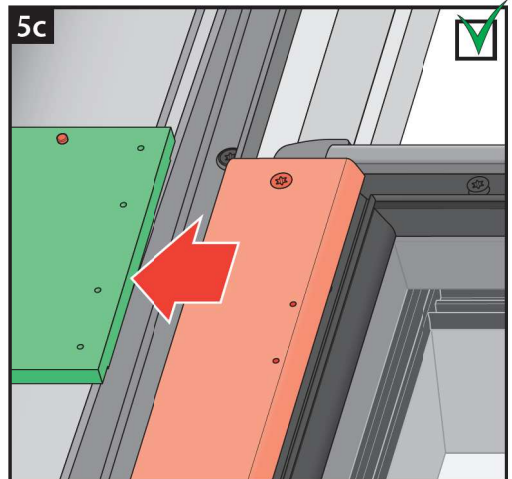
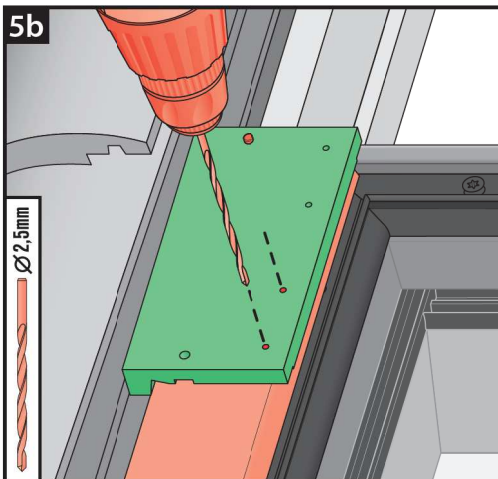
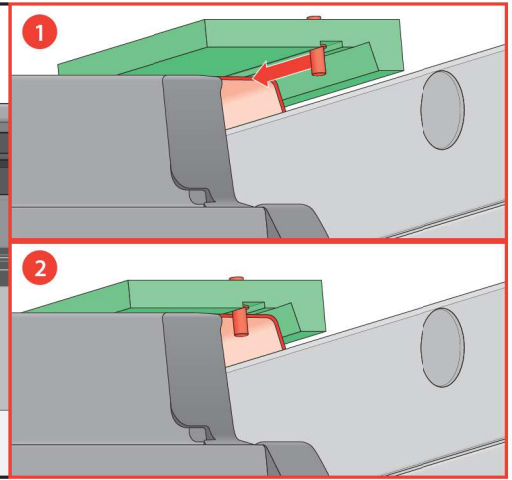
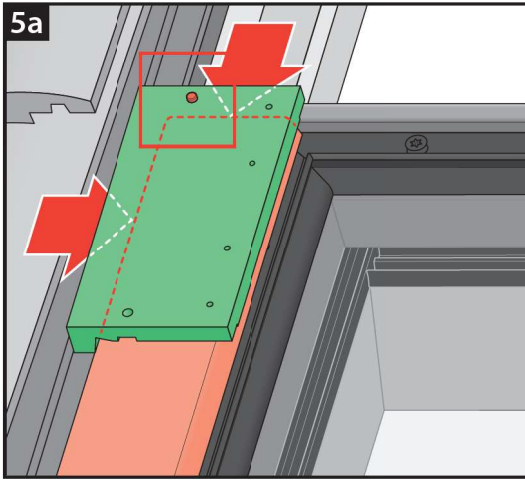
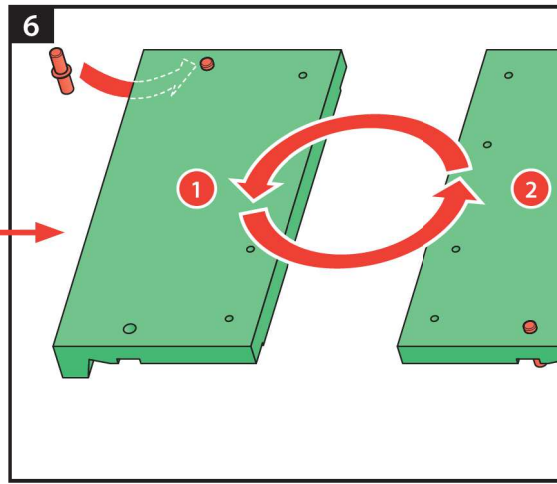
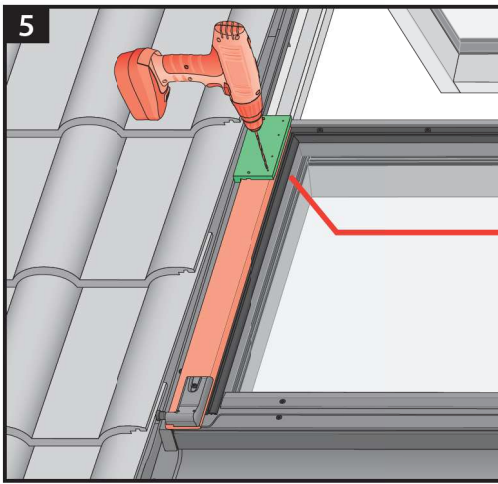

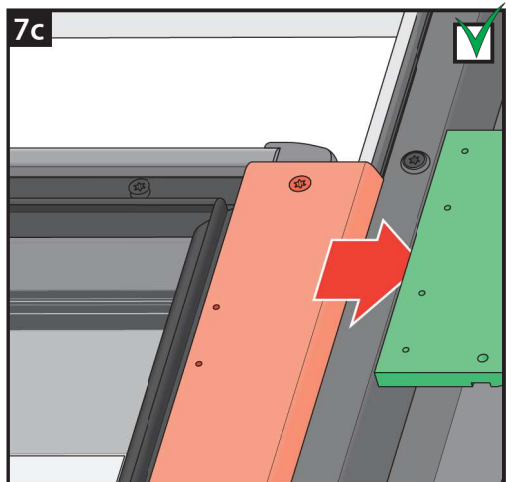
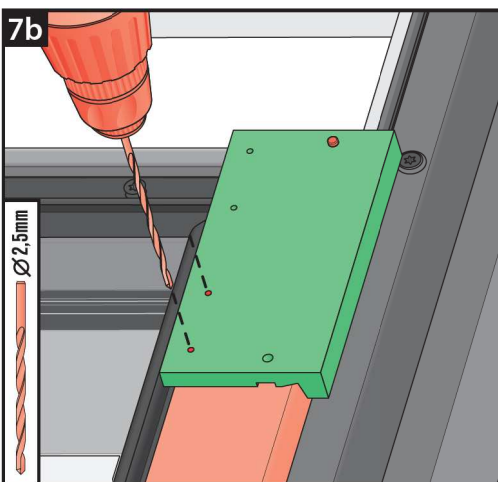
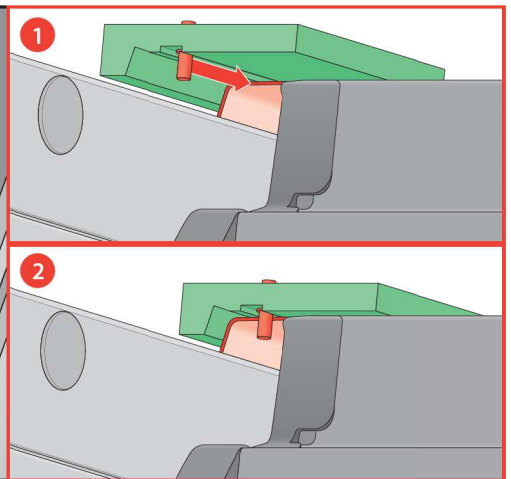
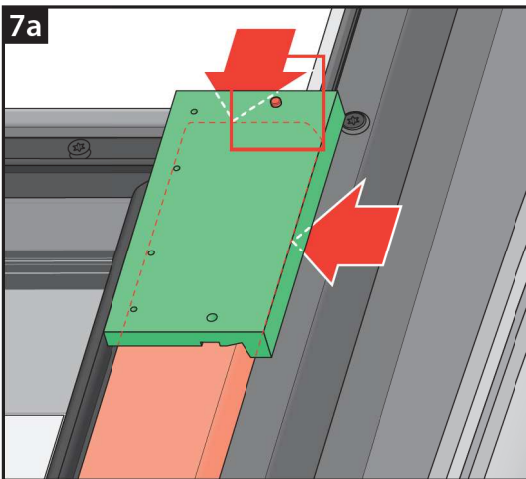
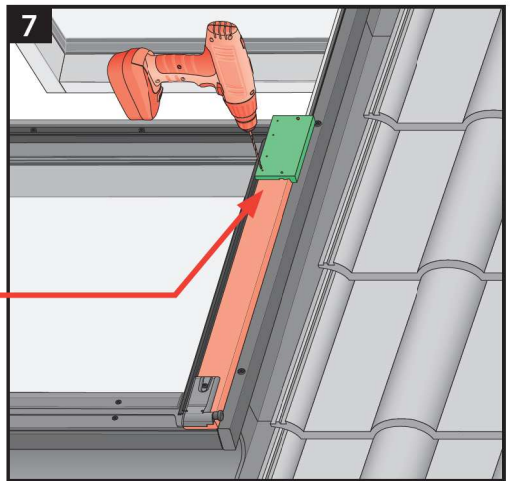
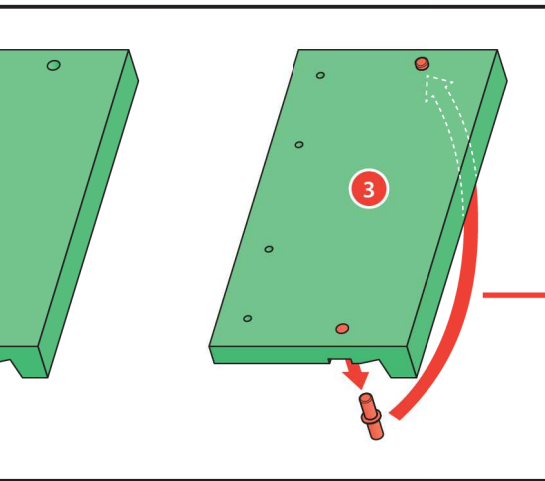

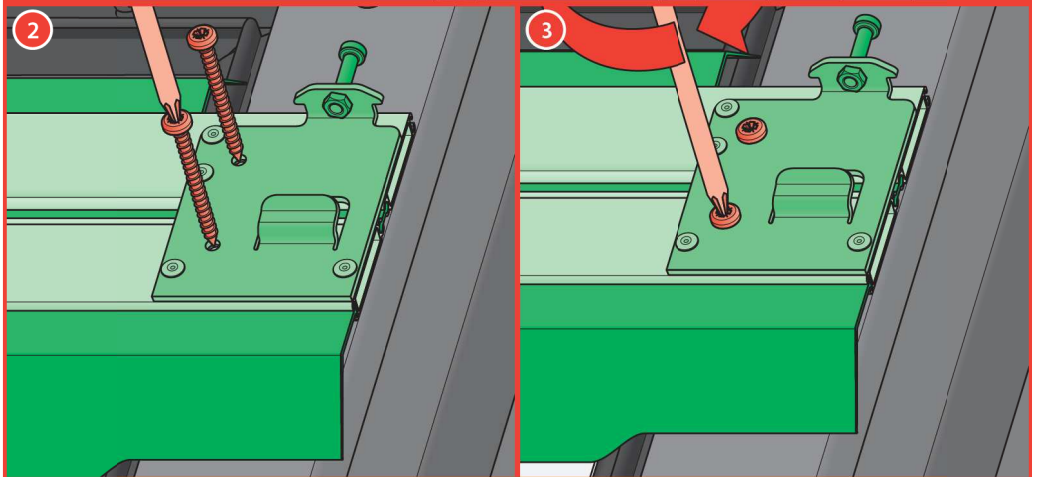
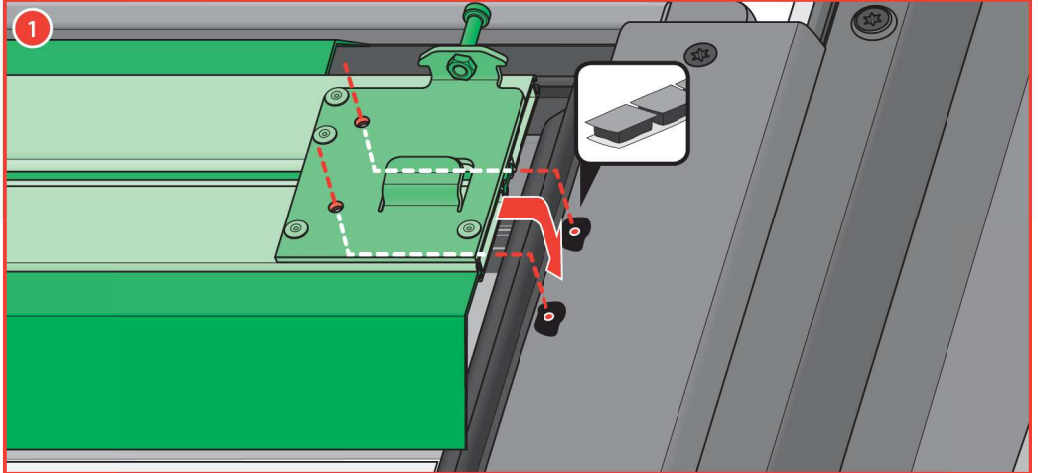
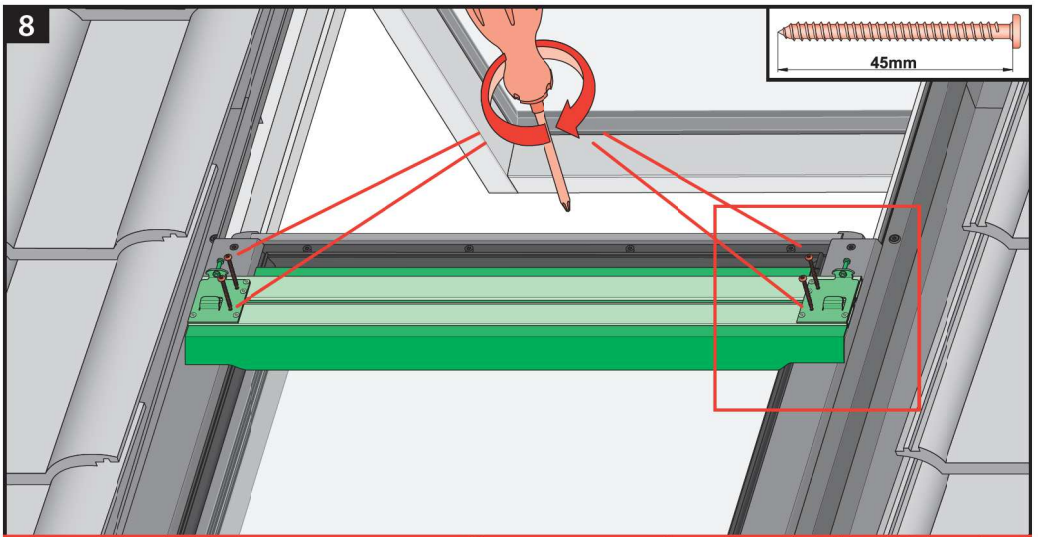

9a

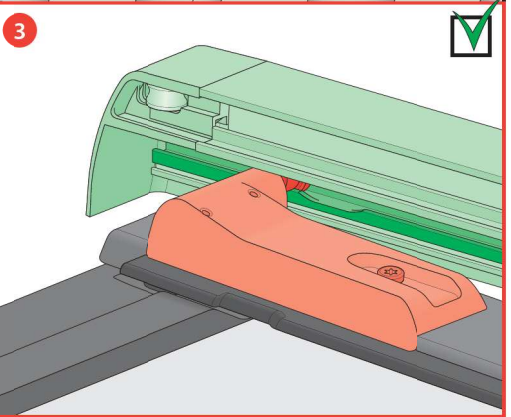
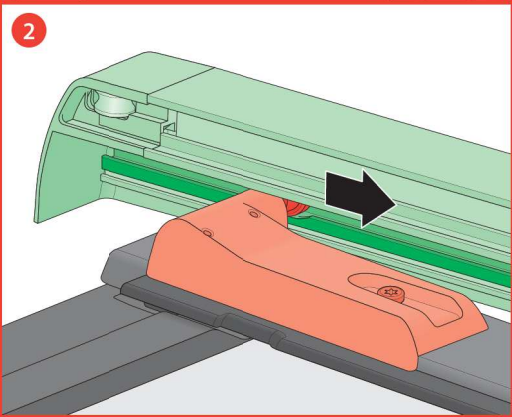
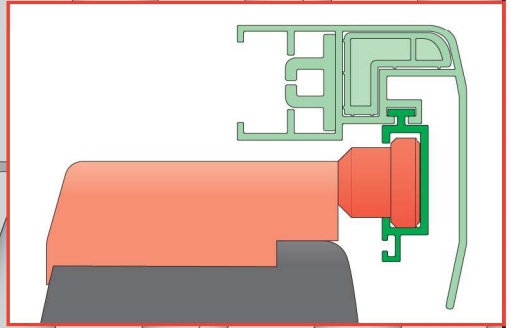
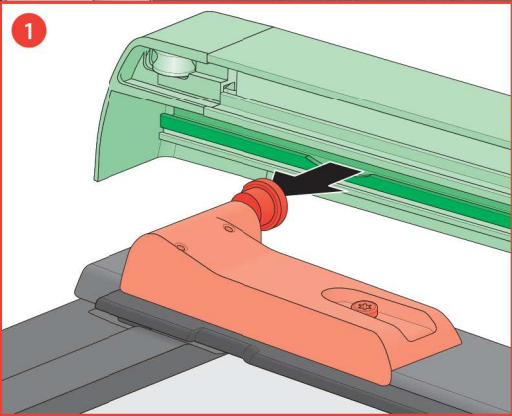
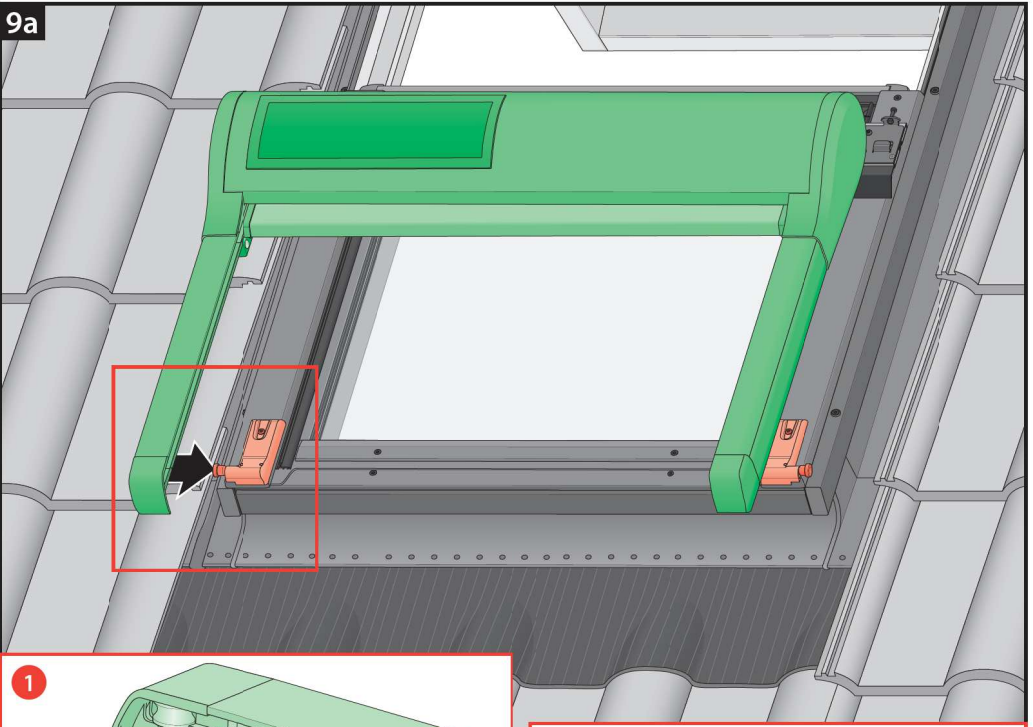

9b

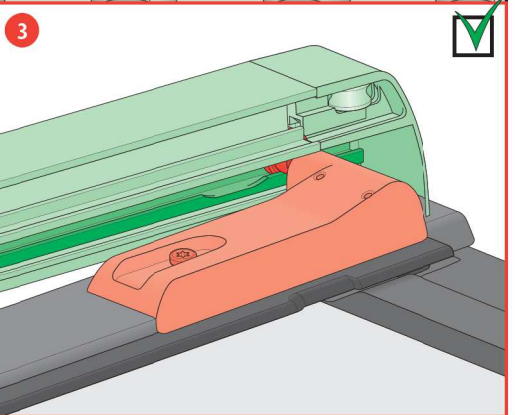
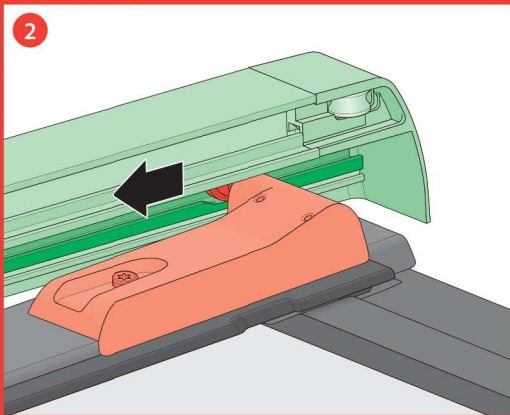
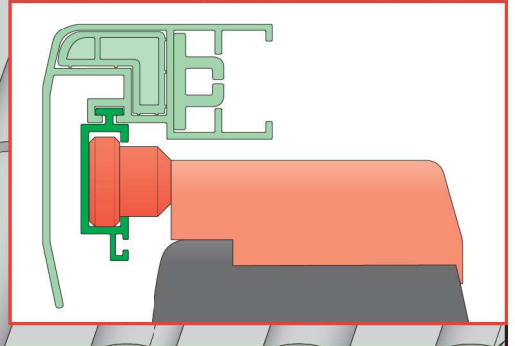
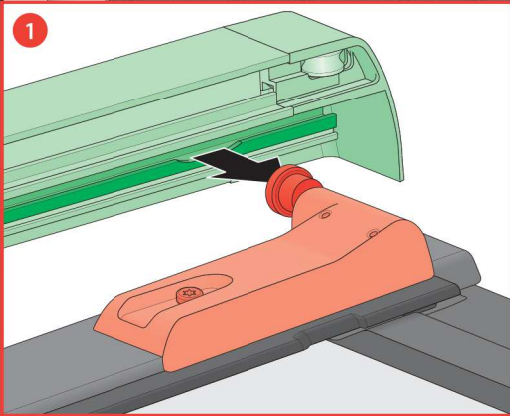
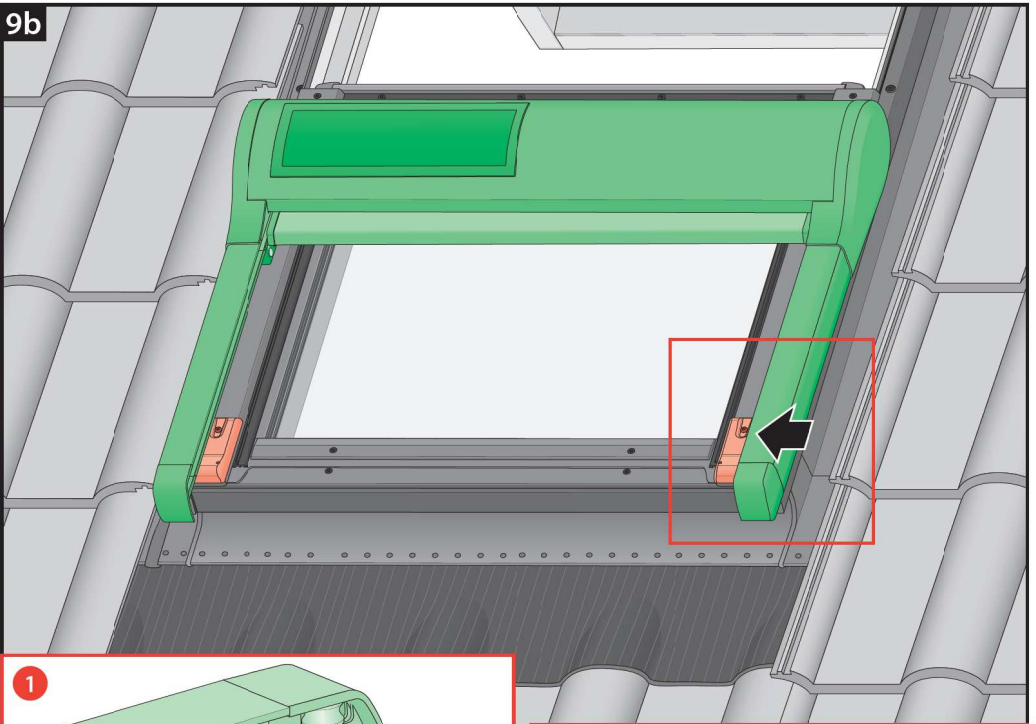

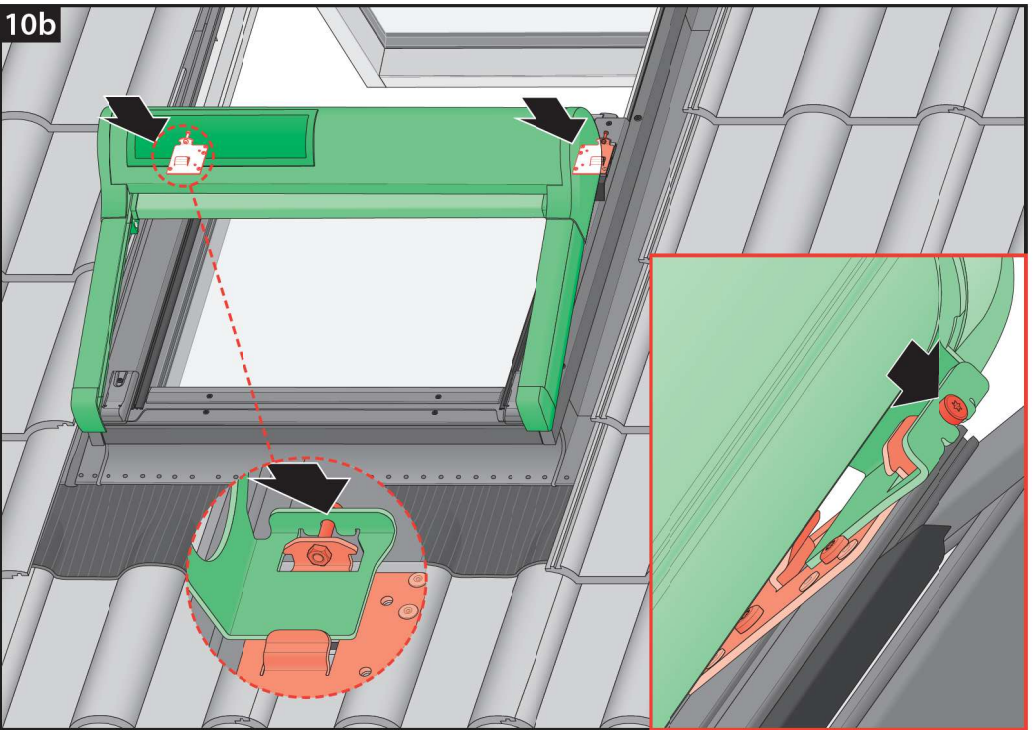
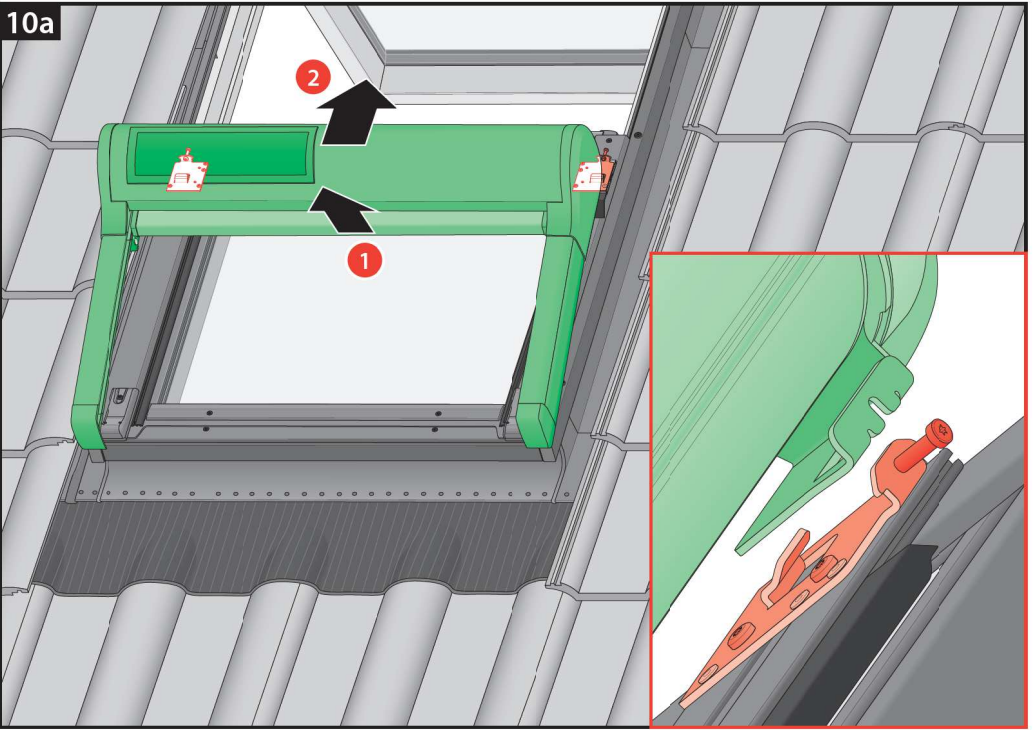

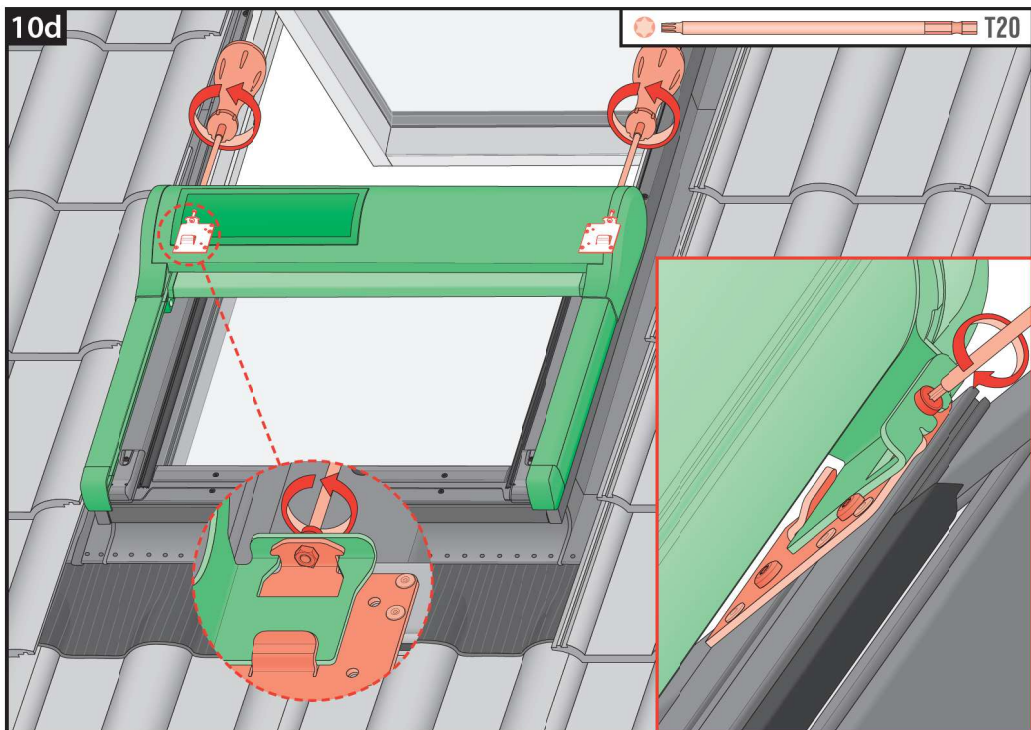
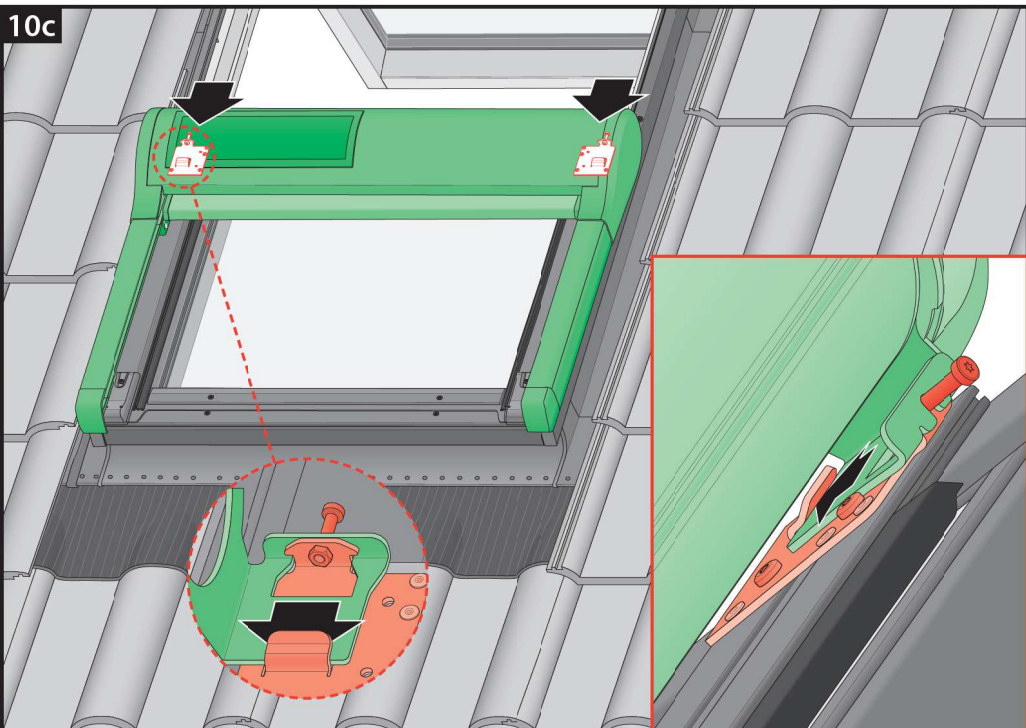

11

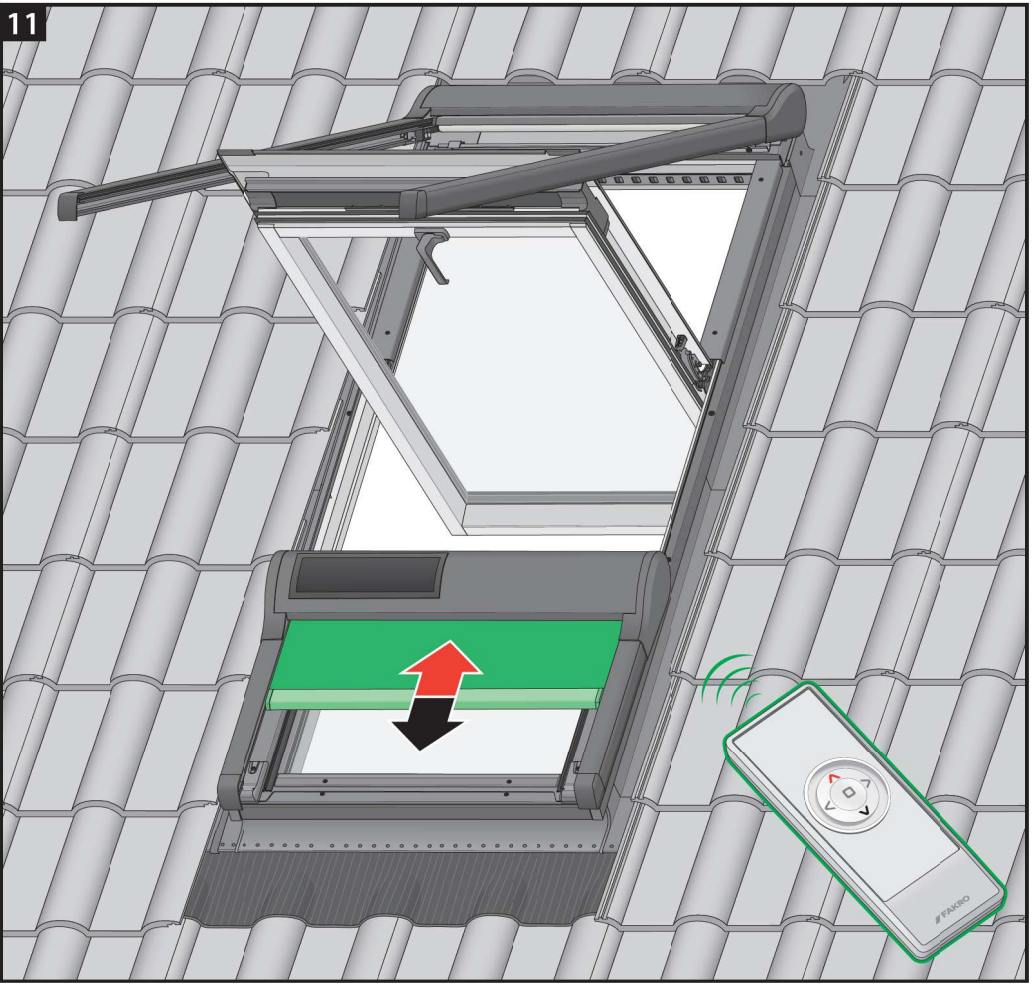

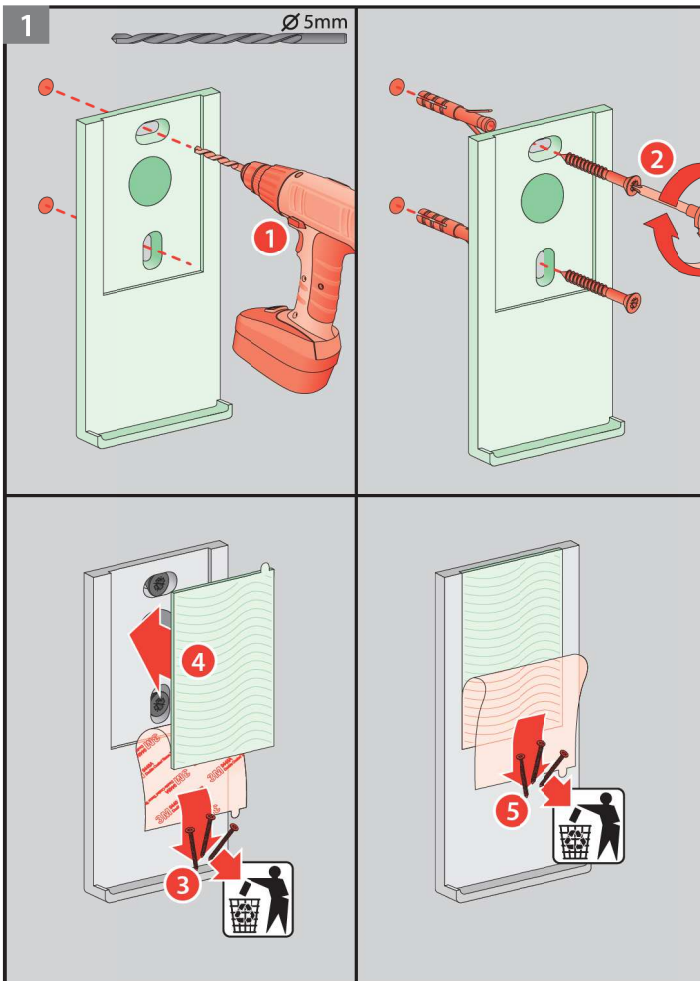

3a

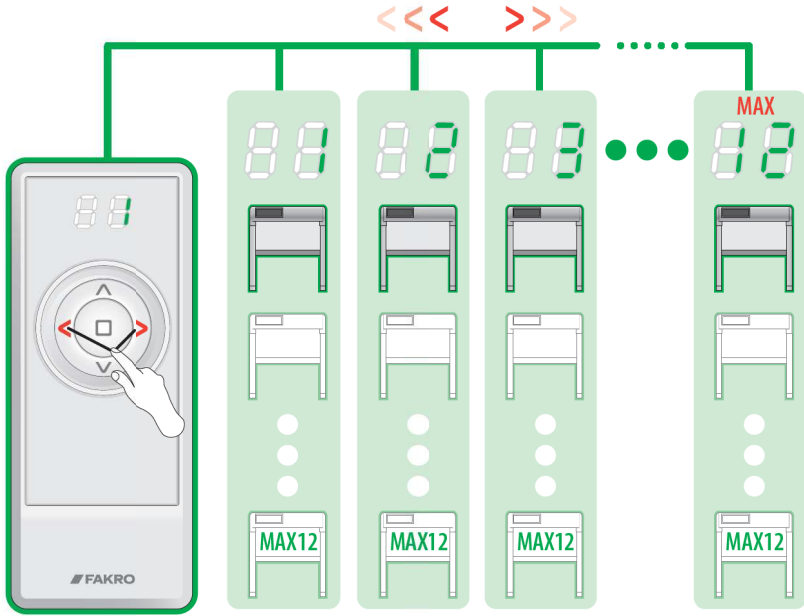

3b

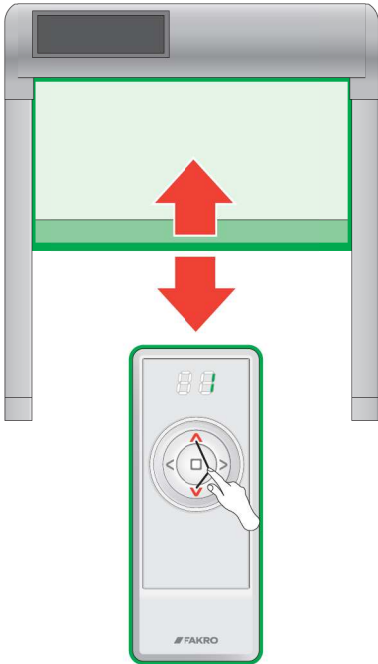

3c

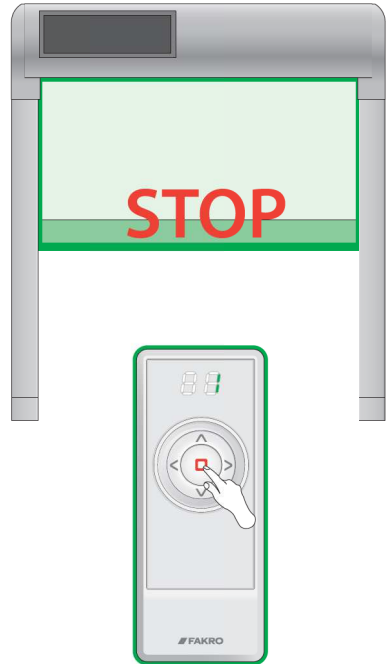

PL	Przed montażem należy zapoznać się z treścią instrukcji NC9L2 „INSTRUKCJA ORYGINALNA 2/3 Zasady montażu i użytkowania”.
1a	Wsunąć narożnik do prowadnicy markizy.
1b	Wsunąć prowadnicę boczną w korpus markizy.
1c	Przykręcić prowadnicę do korpusu.
1d	Powtórzyć czynności 1a-1c dla prowadnicy lewej.
1e	Zamontować baterię pod kasetą markizy.
2	Otworzyć górne okno.
2*	W przypadku okna FXP zdemontować profile zewnętrzne.
3, 3a, 3b, 3c	Zamontować dodatkowe podkładki pod profilami trapezowymi okna.
3d, 3e, 3f, 3g, 3h	Zamontować uchwyty dolne markizy do profili trapezowych okna.
3i	Powtórzyć czynności 3a-3h dla strony lewej.
4a, 4b	Zamontować profile zewnętrzne okna.
5, 5a, 5b, 5c	Użyć szablonu w celu wykonania otworów montażowych.
6	Przełożyć korek pozycjonujący na drugą stronę szablonu.
7, 7a, 7b, 7c	Analogicznie wykonać otwory z drugiej strony okna.
8	Zamontować podstawę montażową markizy.
9a	Wsunąć uchwyt dolny markizy w prowadnicę.
9b	Analogiczną czynność wykonać dla prowadnicy lewej.
10a, 10b, 10c	Nasunąć kasetę markizy na uchwyt górny.
10d	Przykręcić kasetę markizy do uchwytów górnych.
11	Sterować markizą za pomocą pilota.

EN	Before installation, it is compulsory to read the NC9L2 „ORIGINAL INSTRUCTIONS 2/3 Installation and user manual”.
1a	Slide the corner into the awning guide rail.
1b	Slide the side guide rail into the awning casing.
1c	Screw the guide rail to the casing.
1d	Repeat steps 1a-1c for the left guide rail.
1e	Install the battery under the awning cassette.
2	Open the top window.
2*	For the FXP window, remove the external profiles.
3, 3a, 3b, 3c	Install additional washers under the trapezoidal profiles of the window.
3d, 3e, 3f, 3g, 3h	Install the awning bottom holders to the trapezoidal profiles of the window.
3i	Repeat steps 3a-3h for the left side.
4a, 4b	Install the external profiles of the window.
5, 5a, 5b, 5c	Use the template to drill mounting holes.
6	Move the positioning plug to the other side of the template.
7, 7a, 7b, 7c	Similarly, drill holes on the other side of the window.
8	Install the awning mounting base.
9a	Slide the awning bottom holder into the guide rail.
9b	Carry out the same step for the left guide rail.
10a, 10b, 10c	Place the awning cassette onto the top holder.
10d	Screw the awning cassette to top holders.
11	Operate the awning using remote control.



CZ	Výrobce ani prodejce nenese žádnou odpovědnost za porušení příslušných platných zákonů, stavebních předpisů a bezpečnostních požadavků uživatelem výrobku, architektem, montážníkem nebo vlastním klem budovy.
ES	El fabricante y el vendedor no tienen ninguna responsabilidad por el incumplimiento de la ley vigente, normas de construcción y exigencias de seguridad por parte de usuario del producto, arquitecto, instalador o el propietario del edificio.
GB	Manufacturer and Seller shall bear no liability for failure to comply with the applicable laws, building codes and safety requirements by the user of the product, architect, fitter or owner of the building.
IT	Il Produttore e il Rivenditore non potranno essere ritenuti responsabili per il mancato rispetto, da parte dell'utente del prodotto, del progettista, dell'installatore o del proprietario dell'edificio, delle leggi vigenti, nonché dei regolamenti edilizi e di quelli relativi alla sicurezza.
PL	Producent i sprzedawca nie ponosi żadnej odpowiedzialności za nieprzestrzeganie stosownych przepisów prawa, przepisów budowlanych i wymogów bezpieczeństwa przez użytkownika produktu, architekta, montażystę lub właściciela budynku.
RO	Nici producătorul, nici distribuitorul nu sîi vor asuma nîciun fel de rîspundere pentru nerespectarea legilor în vigoare, a legilor din domeniul construcțiilor sau a măsurilor de siguranță impuse utilizatorilor produsului, arhitecților, montajistilor sau proprietarilor clădirii.
SK	Výrobca a predávka nenese žádnou zodpovednosť za neobdobenie príslušných ustanovení zákona, stavebných predpisov a bezpečnostných požiadaviek užívateľom výrobku, architektom, montážom alebo majiteľom objektu.

DE	Hersteller und Verkäufer übernehmen keine Haftung für Nichtbeachtung entsprechender Rechts- und Bauvorschriften sowie Sicherheitsanforderungen seitens Produktbenutzers, Architekten, Monteure oder Gebäudebesitzer.
FR	Le fabricant et le vendeur ne prend aucune responsabilité de ne pas respecter les lois applicables, les règlements sur les bâtiments et les exigences de sécurité par l'utilisateur du produit, l'architecte, l'installateur ou le propriétaire du bâtiment.
HU	A Gyártó és a Forgalmazó nem vállal semmiféle felelősséget a vonatkozó törvényi, építési és biztonsági előírások, építész, telepítőmester vagy építéltulajdonos által be nem tartásáért.
NL	De fabrikant en de venditor zijn niet aansprakelijk voor gevolgen bij het niet opvolgen van toepasselijke wettelijke, bouwvoorschriften en veiligheidsvoorschriften door de gebruiker van het product, de architect, de installateur of de eigenaar van het gebouw.
PT	O fabricante e o vendedor não tem nenhuma responsabilidade pelo o não cumprimento da lei, códigos de construção e as exigências de segurança por parte do usuário do produto, arquiteto, instalador ou proprietário do edifício.
RU	В случае несоблюдения архитектором, монтажником или владельцем здания строительных правил и норм безопасности ответственность с производителя и продавца снимается.